

**CONTROL
PANEL**

RIELLOtech

CLIMA MIX

**INSTALLATION, OPERATION AND
MAINTENANCE MANUAL**

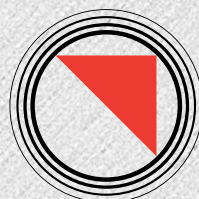
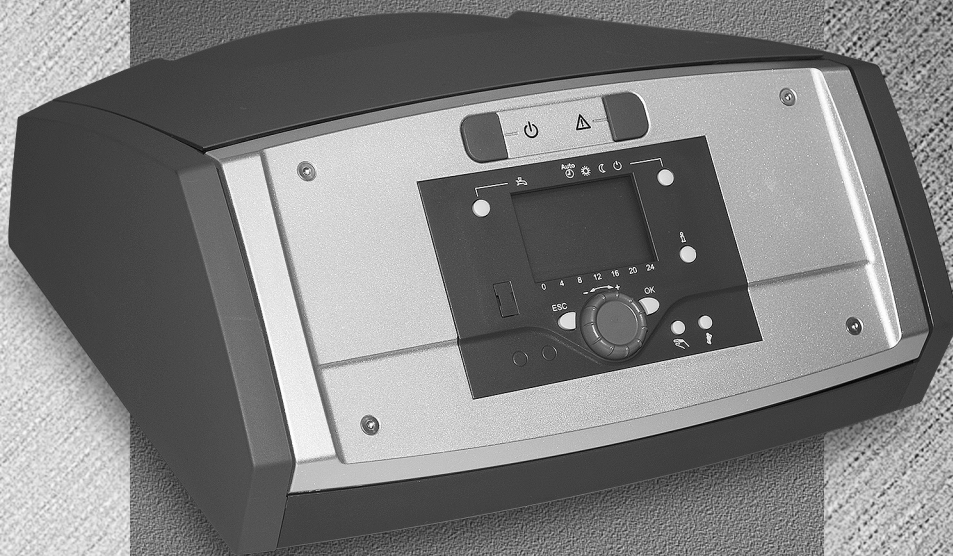

RIELLO

RIELLO S.p.A.

Via Ing. Pilade Riello, 7
37045 Legnago (VR)
Tel. +39 0442630111

RIELLO S.p.A.
Società con Socio unico soggetta alla
direzione e coordinamento di Riello Group SPA
Sede legale e amministrativa
37045 Legnago (VR)
Via Ing. Pilade Riello, 7
Cap. soc. € 7.117.400,00 i.v.
Reg. delle Imp. di Verona N. 02641790239
C.F. e Part. IVA 02641790239

Lecco, 18th January 2012

The company

**Riello SpA Heating Products Direction
Via Risorgimento 13
23900 Lecco
ITALY**

hereby declares that the control panels bearing the brand: **RIELLO**

models:

**RIELLOtech CLIMA COMFORT, RIELLOtech CLIMA TOP,
RIELLOtech CLIMA MIX, RIELLOtech PRIME and RIELLOtech PRIME ACS**

conform to European Directive 2004/108/EC (Electromagnetic Compatibility), to European Directive 2006/95/EC (Low Voltage) and to the following European standards:

EN 60730-1:2000	Automatic electrical controls for household and similar use.
EN 60730-2-9:2000	Part 2: Particular requirements for temperature sensing controls.
EN 60529:1992	Specification for degrees of protection provided by enclosures (IP code).
EN 61000-6-2:2001	Electromagnetic compatibility. Immunity per industrial environments.
EN 61000-6-3:2001	Electromagnetic compatibility. Emission standard for residential, commercial and light-industrial environments.



Marco Tagliaferri
Heating Products Director
Riello S.p.A.

Dear heating engineer,

Congratulations on having chosen a **RIELLOtech** control panel. You have selected a modern, quality product that is designed to give dependable, efficient and safe service and to provide comfort in the home for many years to come. This manual provides information that is essential to the installation of the appliance. Used in conjunction with your own knowledge and expertise it will enable you to install the appliance quickly, easily, and correctly.

Once again, please accept our thanks and our congratulations on your choice of product.

Riello S.p.A.

RANGE

MODEL	CODE
RIELLOtech CLIMA MIX	20010428

CONTENTS

General safety information	5
Precautions	5
Product description	6
Identification	6
Technical specifications	7
Accessories	7
Unpacking the product	7
Dimensions and weight	8
Assembly	9
Access to internal components	10
Electrical connections	10
Positioning the sensors	12
Connecting the outdoor temperature sensor	13
Wiring diagrams	15
Layout	17
Description of functions	18
Mode selection	20
User levels	23
Error/maintenance codes	25
List of parameters	28
Useful information	41

The following symbols are used in this manual:







= Identifies actions that require caution and adequate preparation.



= Identifies actions that you MUST NOT do.







This manual, Code 20013519 - Rev. 2 (06/12) is made up of 44 pages.

GENERAL SAFETY INFORMATION

-  Check that the product is complete and undamaged as soon as you remove it from its packaging. Contact the **RIELLO** reseller from whom you purchased the product if you notice any problems.
-  This product must be installed by a legally qualified heating engineer. (In Italy heating engineers are regulated by law no. 37 of the 22/01/2008.) On completion of the installation, the installer must issue the owner with a declaration of conformity confirming that the installation has been completed to the highest standards in compliance with the instructions provided by **RIELLO** in this instruction manual, and that it conforms to all applicable laws and standards.
-  The manufacturer declines all responsibility, contractual or other, for damage to property or injury to persons or animals caused by improper installation, adjustment, maintenance or use.
-  This instruction manual is an integral part of the product. It must be kept safe and must ALWAYS accompany the product, even if it is sold to another owner or transferred to another user or to another installation. If you damage or lose this manual, order a replacement immediately from your local **RIELLO** Technical Assistance Centre.

PRECAUTIONS

The operation of any appliance that uses electrical power demands that a number of fundamental safety precautions be respected. In particular:

-  Always turn the **electrical power supply OFF** at the main switch before commencing any cleaning or maintenance.
-  Do not tamper with or adjust the safety or control devices without prior authorisation and instructions from the boiler's manufacturer.
-  Never pull, disconnect, or twist the electrical cables coming from the appliance even if it is disconnected from the mains electricity supply.
-  Dispose of packaging materials in compliance with applicable standards and legislation governing the disposal of urban, domestic and industrial waste.
-  Never switch the control panel on even for a short period if the safety devices are not functioning correctly or have been tampered with.
-  All maintenance and repairs must be carried out by a legally qualified heating engineer.
-  Do not use water to extinguish fire in the control panel. Switch power OFF at the mains power switch to isolate the control panel electrically first. Then use a class E fire extinguisher (marked "SUITABLE FOR LIVE ELECTRICAL ITEMS") to extinguish the flames.

PRODUCT DESCRIPTION

RIELLOtech CLIMA MIX control panels are designed to control 1 mixed zone, or 2 with the addition of an expansion kit.

The microprocessor technology of the electronic controller makes these control panels ideal for use with various types of heating system, even with different minimum and maximum temperatures. The units are programmed by means of parameter settings on the built-in display that are only accessible to trained and authorised personnel. All electric and electronic control devices comply with applicable technical and safety standards, and are housed in an ABS box.

All the control and safety devices in **RIELLOtech CLIMA MIX** control panels are factory tested in compliance with applicable technical standards.

RIELLOtech CLIMA MIX control panels are only designed for vertical installation (e.g. on the side panel of a wall-mounted boiler).

A kit for separate wall mounting is also available on request.

APPLICATION CHART

	Burner type	Cascaded boilers	Biomass fuelled boilers	Solar water heating systems	DHW storage cylinders	Direct zone	1 st mixed zone	2 nd mixed zone
RIELLO tech CLIMA MIX								2-stage with kit

IDENTIFICATION

RIELLOtech control panels are identified by:

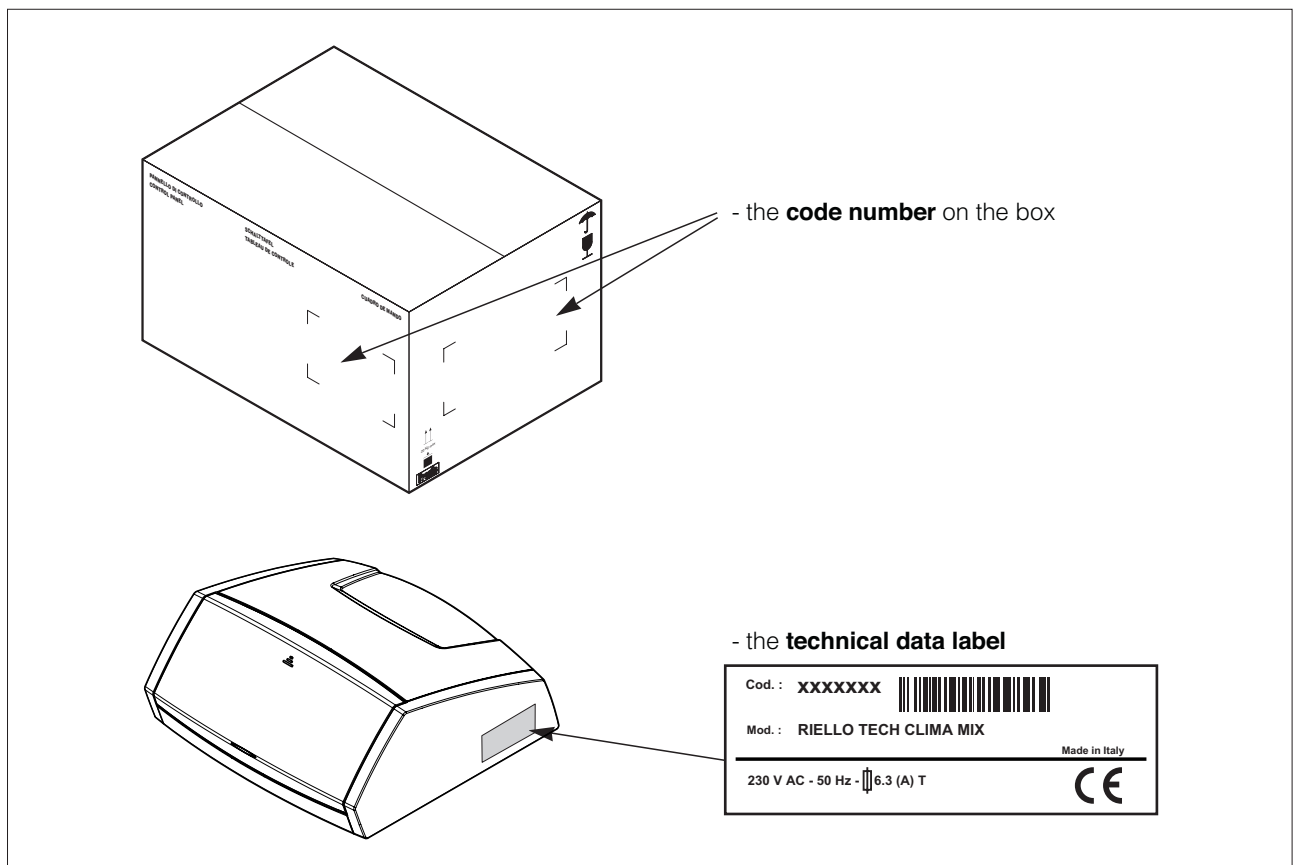

TECHNICAL SPECIFICATIONS

Description	RIELLOtech CLIMA MIX	
Power supply	230 (+/-10%) - 50	V - Hz
Main power switch (two pole)	250 - 10(4)	V - A
Fuse (on internal terminal block)	250 - 6,3 T	V - A
Max power input (electronic controller)	9	VA
Electronic controller relay contacts for burner and pumps	250 - 2(2)	V - A
Index of protection	20	IP

ACCESSORIES

The following accessories are available, to be ordered separately.

ACCESSORY	CODE
Pipe thermostat, NTC 10 k Ω for RVS (QAD36/101)	20008753
Outdoor temperature sensor, NTC 1 k Ω for RVS (QAC34/101)	4047947
Immersion type boiler flow and return temperature sensor, NTC 10 k Ω for RVS (L = 5m)	20010068
Room temperature sensor	20012456
RC2 Remote Control – programmable	4334410
Wall mounting kit (for use only with vertical installation versions)	20010056
Additional mixed zone control kit	20011194

UNPACKING THE PRODUCT

RIELLOtech control panels come in a cardboard box that also contains the following accessories:

- Self-tapping fixing screws
- Instruction manual.

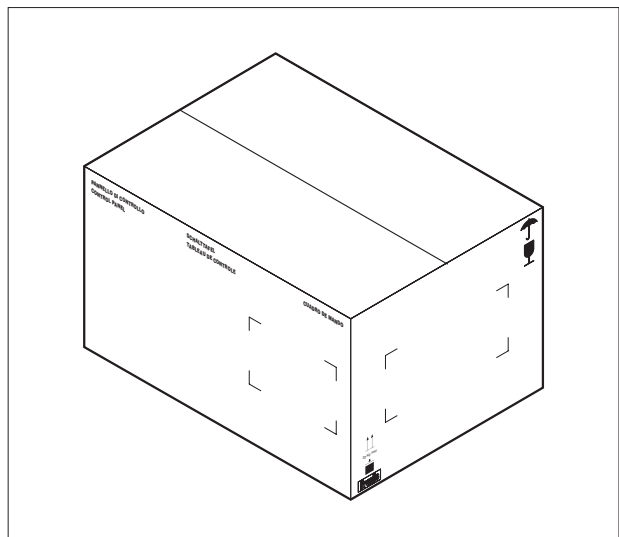

DIMENSIONS AND WEIGHT

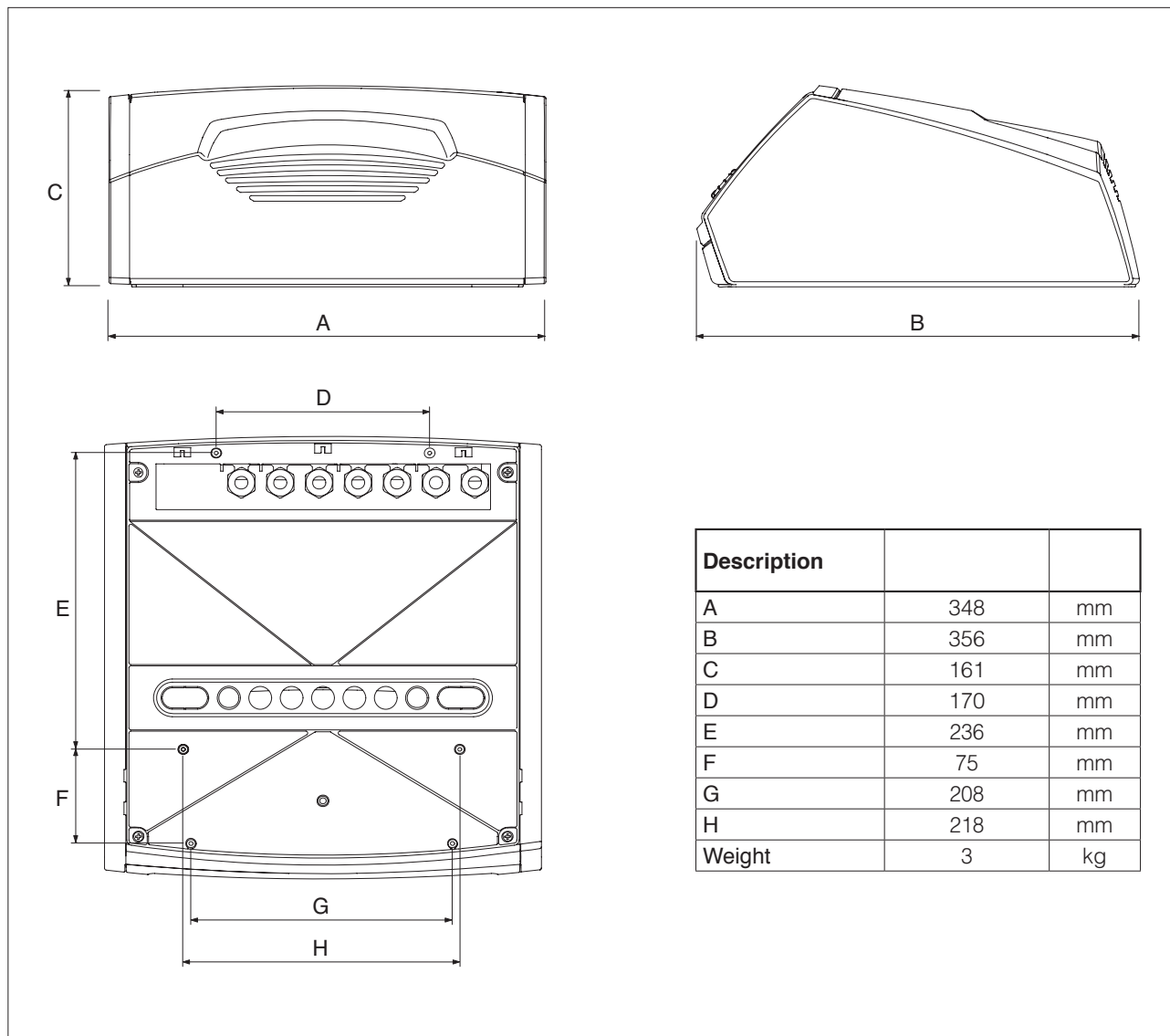

RIELLOtech Clima Mix control panels can be installed on one of the side panels of boilers with suitable provision.

Before commencing installation, check the arrangement of the holes on the side panel of the boiler.

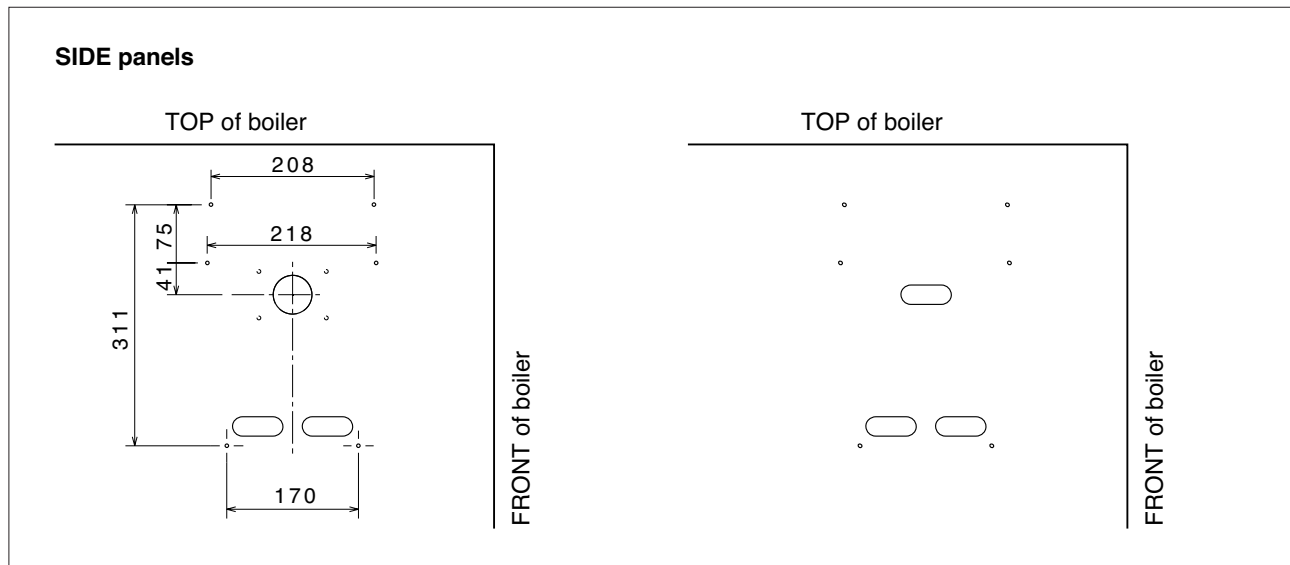

Once you have identified the right holes for the type of installation required, proceed as follows.

- Push out the pre-formed slots on the boiler casing corresponding to the oval cable grommets in the control panel.
- Perforate the membranes of the control panel cable grommets. Pull out the thermostat cable and route it through the slot in the top panel.
- Fix the control panel to the boiler casing using the screws provided.

A dedicated kit is available for wall mounting. Refer to the instructions provided with the kit for details on installation.

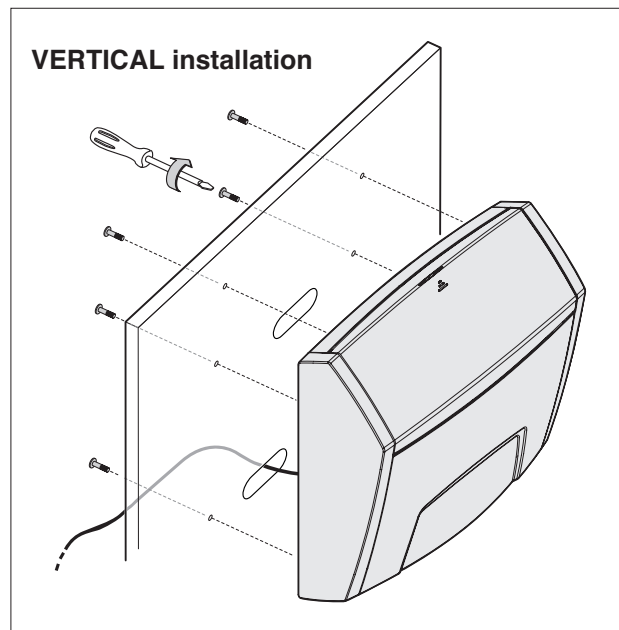

ACCESSING INTERNAL COMPONENTS

Only personnel from Riello's Technical Assistance Service or professionally qualified heating engineers are allowed to access components inside the control panel.

Proceed as follows if you need to access components inside the control panel:

- Turn the system OFF at the mains power switch.
- Tilt the panel (1) forwards. Remove the 2 fixing screws (2) and remove the top cover (3).

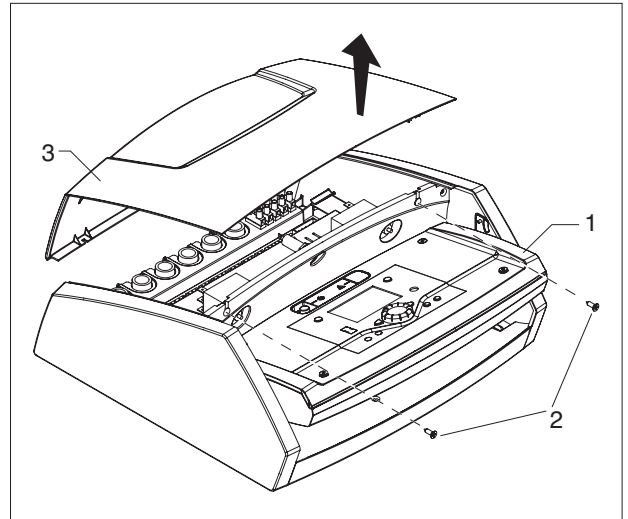

ELECTRICAL CONNECTIONS

All electrical connections must be made by a legally qualified heating engineer according to the following instructions. (In Italy heating engineers are regulated by law no. 37 of the 22/01/2008.)



The following instructions are mandatory.

- 1 - Use a multi-pole magnetic thermal trip switch and disconnecter conforming to IEC-EN standards (with a contact gap of at least 3 mm).
 - 2 - Respect the L (Phase) - N (Neutral) polarity. Keep the ground wire about 2 cm longer than the power wires.
 - 3 - Use cables with a cross section of 1.5 mm² or more, complete with end terminals.
 - 4 - Always refer to the electrical wiring diagrams in this manual when performing any electrical work.
 - 5 - Make sure the appliance is connected to an effective ground.
- Proceed as instructed in the "ACCESSING INTERNAL COMPONENTS" section above to access the terminals inside the control panel.
 - Route the control panel power cables and all the cables to be connected to the 'load side' of the main board through the cable grommets (A) in the bottom of the control panel.
 - Route the cables to be connected to the 'sensor side' of the main board through the cable grommets (B) and (C) in the bottom of the control panel.
 - Route all these cables through the cable grommets in the casing of the boiler, or use the cable holes for PG type cable clamps or spiral cable duct fittings.
 - Connect up the 230V mains power, using the fixed 'Mamut' terminals, referring to the wiring diagram on the next page and to the WIRING DIAGRAMS chapter.
 - Connect up the individual 230V and +12Vdc devices, referring to the mounting diagram on the next page and to the WIRING DIAGRAMS chapter.
 - Secure the cables to the casing of the boiler so that they cannot be accidentally pulled out.



It is strictly forbidden to use fuel and/or water pipes to ground the appliance.



Do not route the power cable or room thermostat cables near hot surfaces (like heating circuit flow pipes). Use a suitable class of cable if there is any possibility of contact with parts at temperatures above 50°C.

The manufacturer declines all responsibility for damage caused by failing to ground the appliance adequately or by failure to respect the wiring diagrams provided in this manual.

POSITIONING THE SENSORS

Correct positioning of the temperature sensors is essential to proper indoor climate control.

⚠ To ensure correct functioning, use separate cable ducts for the power cables (230 Vac) and for the non-polarised terminals.

SI (CH circuit temperature sensor)

Insert in the socket for mixed zone temperature control.

To measure effective water return temperature and to control the temperature stabilisation function, the socket for the return temperature sensor must be positioned at a distance of 3 to 5 times the diameter of the water return pipe upstream from any water fittings (condensate prevention pump or recirculation pump).

If the boiler provides no socket for an immersion type sensor, use the accessory external pipe sensor, to be ordered separately.

Maximum permitted sensor cable lengths (copper)

Cable size	0,25	0,50	0,75	1,0	1,5	mm ²
Max. length	20	40	60	80	120	m

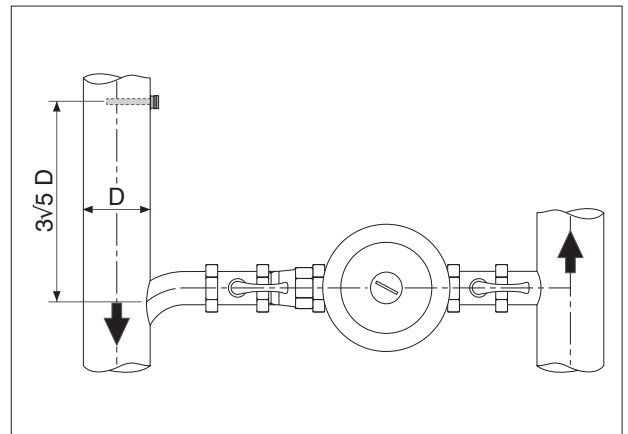

Correspondence table

CH CIRCUIT TEMPERATURE SENSOR

(Available as accessories, to be ordered separately.)

Measured temperature (°C) – Resistance of temperature sensor (Ω).

T (°C)	R (Ω)	T (°C)	R (Ω)	T (°C)	R (Ω)	T (°C)	R (Ω)
-30	175203	30	8059	90	915	150	183
-25	129289	35	6535	95	786	155	163
-20	96360	40	5330	100	677	160	145
-15	72502	45	4372	105	586	165	130
-10	55047	50	3605	110	508	170	117
-5	42158	55	2989	115	443	175	105
0	32555	60	2490	120	387	180	95
5	25339	65	2084	125	339	185	85
10	19873	70	1753	130	298	190	77
15	15699	75	1481	135	262	195	70
20	12488	80	1256	140	232	200	64
25	10000	85	1070	145	206		

CONNECTING THE OUTDOOR TEMPERATURE SENSOR

Correct positioning of the outside temperature sensor is essential to proper indoor climate control. The sensor must be installed outside the building to be heated, about 2/3 of the way up a NORTH or NORTH-WEST facing wall, well clear of any flues, doors, windows and out of direct sunlight.

Fixing the outdoor temperature sensor to the wall

- Unscrew the cover from the sensor casing to access the sensor terminals and fixing holes.
- Use the sensor casing as a template to mark the drilling points on the wall.
- Remove the sensor casing and drill 5x25 holes for the expansion plugs.
- Fix the sensor casing to the wall using the two expansion plugs provided.
- Route a two-core cable from the sensor to the boiler.

Maximum permitted sensor cable lengths (copper)						
Cable size	0,25	0,50	0,75	1,0	1,5	mm ²
Max. length	20	40	60	80	120	m

- Fit the cover on the sensor casing.
- Open the control panel and connect the sensor up as instructed in the "Electrical connections" section. Polarity is irrelevant.
- Once you have made all the necessary connections, close the control panel, reversing the steps followed to open it.

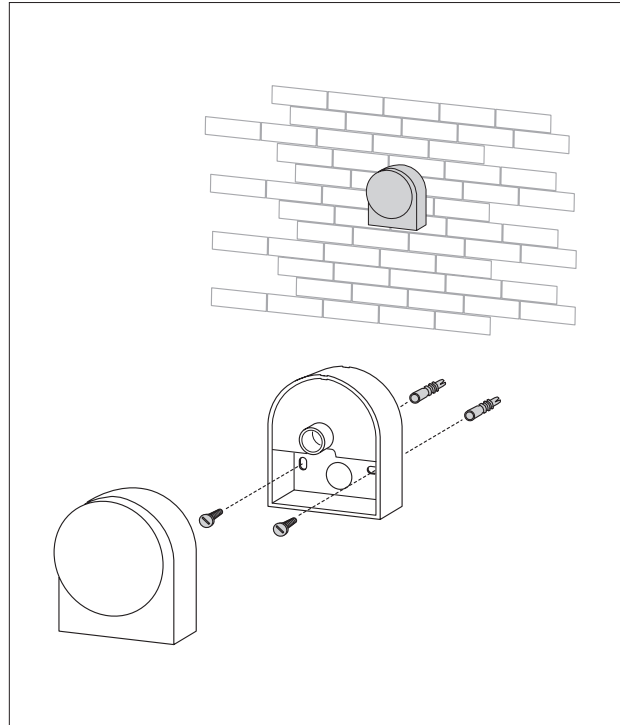

- ⚠ Position the outdoor temperature sensor on a smooth area of wall. Prepare a smooth contact area for the sensor casing if the wall is made from exposed brick or other rough material.
- ⚠ Avoid joins in the cable between the outdoor temperature sensor and the control panel. If different cable lengths have to be joined, make sure that the joins are sealed and adequately protected.
- ⚠ If cable ducts are used to route the sensor connection cable, keep these well clear of any power cables (230Vac).

Correspondence table

Measured temperature (°C) – Resistance of outdoor temperature sensor (Ω).





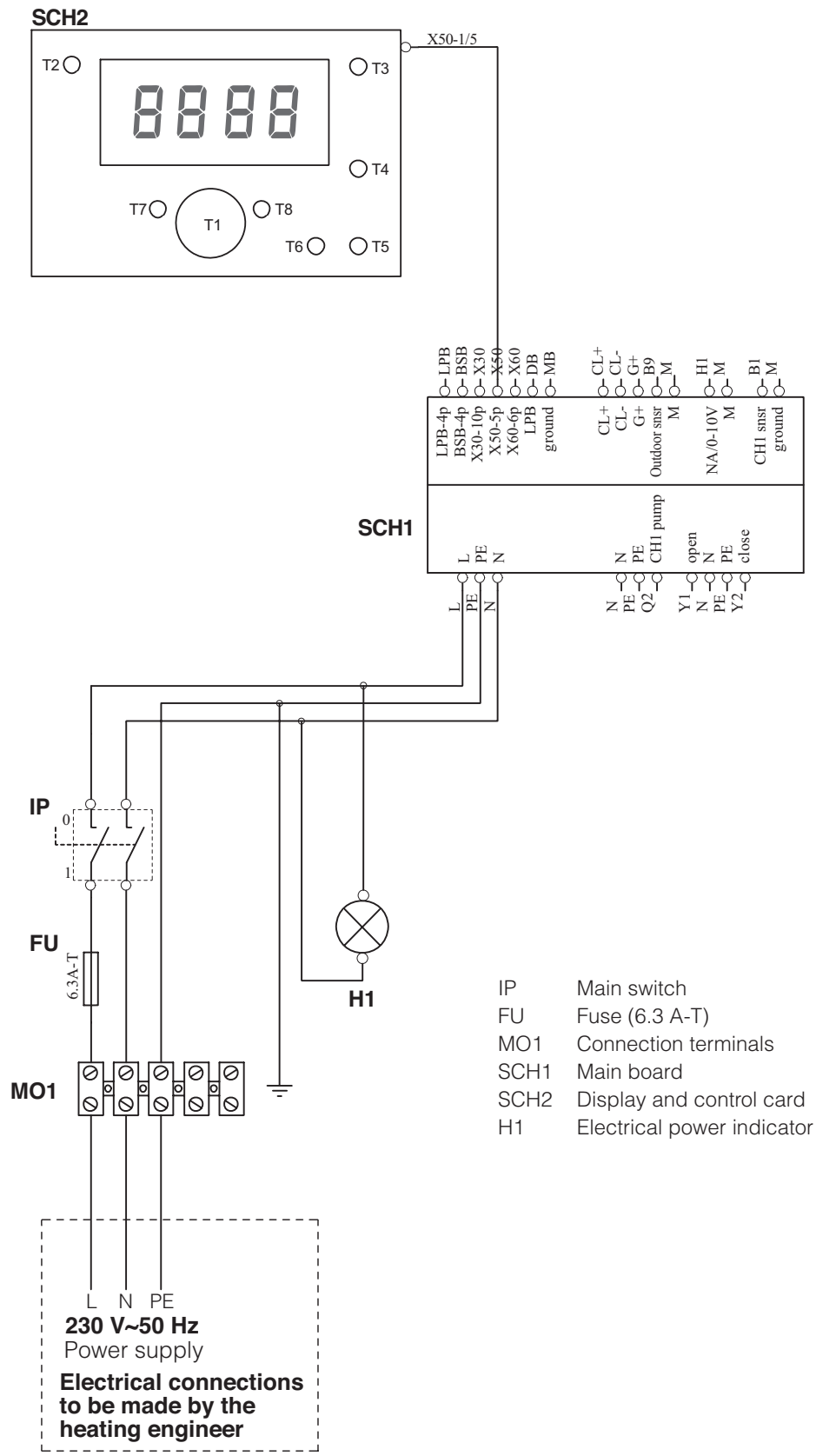

T (°C)	R (Ω)	T (°C)	R (Ω)	T (°C)	R (Ω)	T (°C)	R (Ω)
-30.0	13'034	-9.0	4'358	12.0	1'690	33.0	740
-29.0	12'324	-8.0	4'152	13.0	1'621	34.0	713
-28.0	11'657	-7.0	3'958	14.0	1'555	35.0	687
-27.0	11'031	-6.0	3'774	15.0	1'492	36.0	663
-26.0	10'442	-5.0	3'600	16.0	1'433	37.0	640
-25.0	9'889	-4.0	3'435	17.0	1'375	38.0	617
-24.0	9'369	-3.0	3'279	18.0	1'320	39.0	595
-23.0	8'880	-2.0	3'131	19.0	1'268	40.0	575
-22.0	8'420	-1.0	2'990	20.0	1'218	41.0	555
-21.0	7'986	0.0	2'857	21.0	1'170	42.0	536
-20.0	7'578	1.0	2'730	22.0	1'125	43.0	517
-19.0	7'193	2.0	2'610	23.0	1'081	44.0	500
-18.0	6'831	3.0	2'496	24.0	1'040	45.0	483
-17.0	6'489	4.0	2'387	25.0	1'000	46.0	466
-16.0	6'166	5.0	2'284	26.0	962	47.0	451
-15.0	5'861	6.0	2'186	27.0	926	48.0	436
-14.0	5'574	7.0	2'093	28.0	892	49.0	421
-13.0	5'303	8.0	2'004	29.0	859	50.0	407
-12.0	5'046	9.0	1'920	30.0	827		
-11.0	4'804	10.0	1'840	31.0	796		
-10.0	4'574	11.0	1'763	32.0	767		

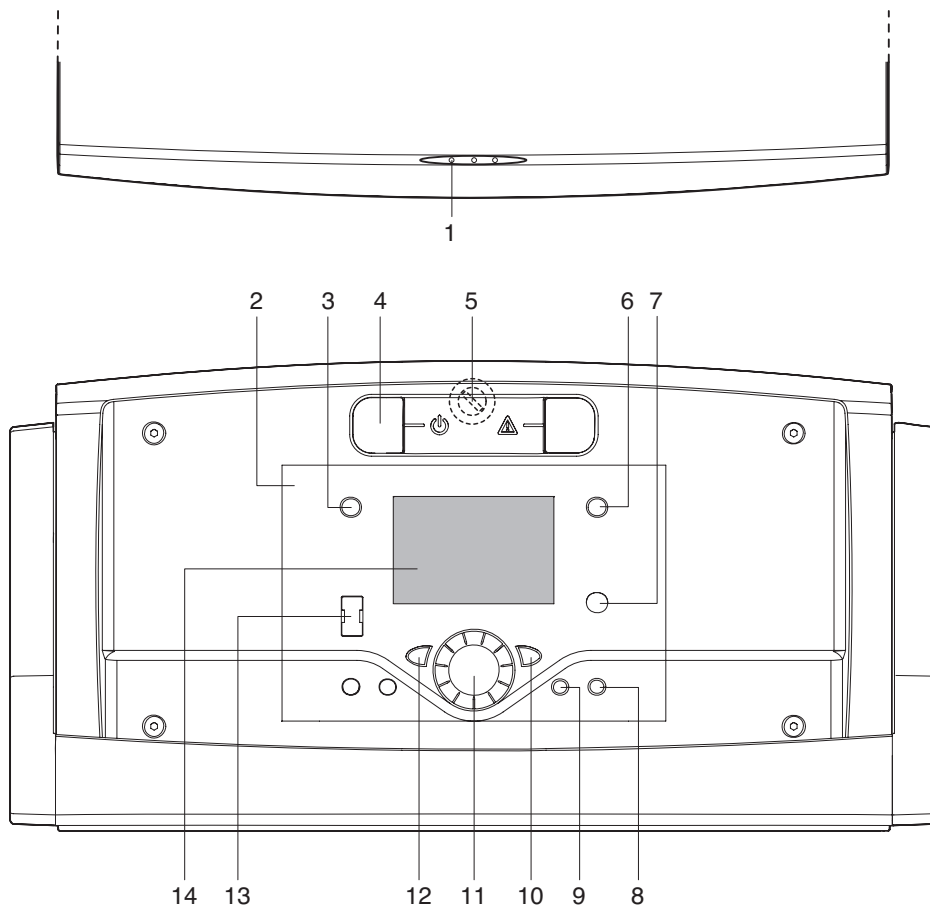
FUNCTIONAL ELECTRICAL DIAGRAM FOR RIELLOtech CLIMA MIX CONTROL PANEL



- IP Main switch
- FU Fuse (6.3 A-T)
- MO1 Connection terminals
- SCH1 Main board
- SCH2 Display and control card
- H1 Electrical power indicator



- | | |
|---|---|
| <p>1 - Electrical power indicator (green).
Lights to show that the system is receiving electrical power.</p> <p>2 - Electronic controller</p> <p>3 - DHW production on/off button
When DHW production is active, the  symbol appears on the display</p> <p>4 - Main switch</p> <p>5 - Fuse (accessible by tilting the control panel)</p> <p>6 - Functioning mode selection button
A line appears under the symbols:</p> <ul style="list-style-type: none">  Automatic: system operates according to the set program.  Continuous: system operates continuously at comfort setpoint.  Reduced: system operates at reduced setpoint.  Stand-by | <p>7 - Information button.</p> <p>8 -  button for chimney sweep/safety thermostat test functions.</p> <p>9 -  button for manual mode.</p> <p>10 - Value confirm (OK) button.</p> <p>11 - Value change knob.</p> <p>12 - ESCape (exit) button.</p> <p>13 - PC BUS connector.</p> <p>14 - Display</p> |
|---|---|

DESCRIPTION OF FUNCTIONS

SECONDARY USER INFORMATION / DISPLAY

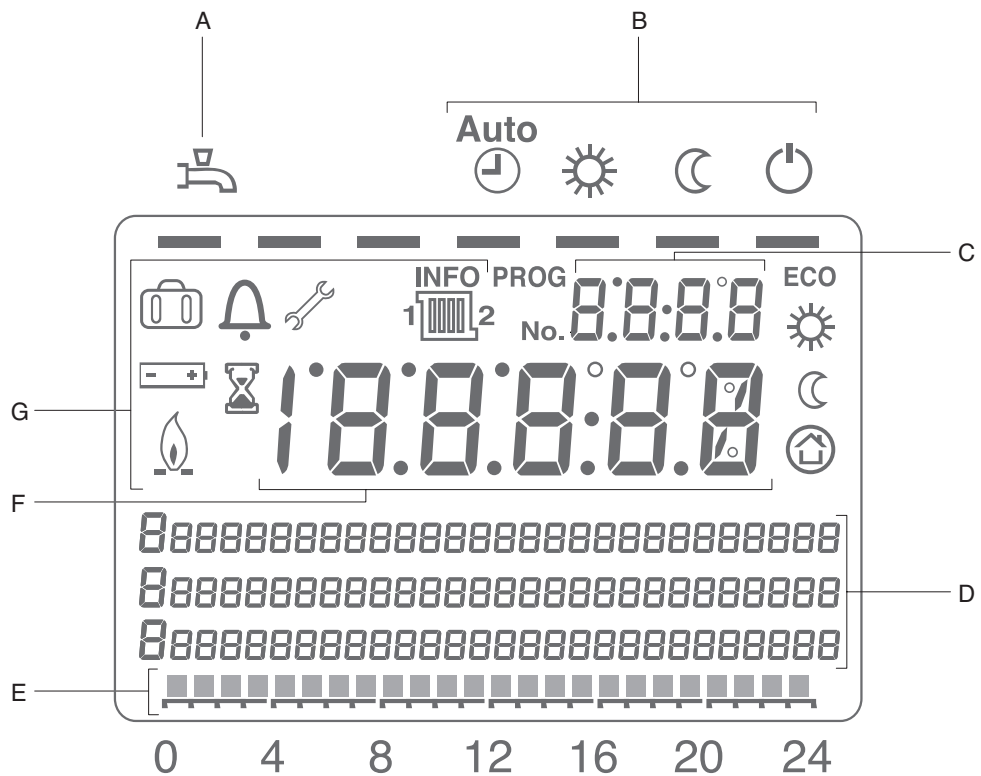

- A - DHW mode: ON or OFF.
- B - Central heating modes:
 - ⌚ AUTOMATIC
 - ☀ Continuous COMFORT
 - ☾ Continuous REDUCED
 - ⏻ Frost protection. The "⏻" symbol is displayed.
- C - Small numeric display: time.
- D - Message area.
- E - Daily heating program indicator.
- F - Large numeric display: current value.
- G - Display symbols:
 - 🔥 Burner running
 - ⊖ ⊕ Change battery (room unit only, not supplied)
 - 🏠 Holiday mode active
 - 🔔 Error. Press the **i** button to display the error message
Press **ESC** to return to the main screen
 - ⌚ Wait: process running
 - 🔧 Maintenance - manual or chimney sweep mode
 - 🏠₂ Reference to heating circuit
 - ECO** Heating temporarily OFF - ECO mode active

STANDARD DISPLAY

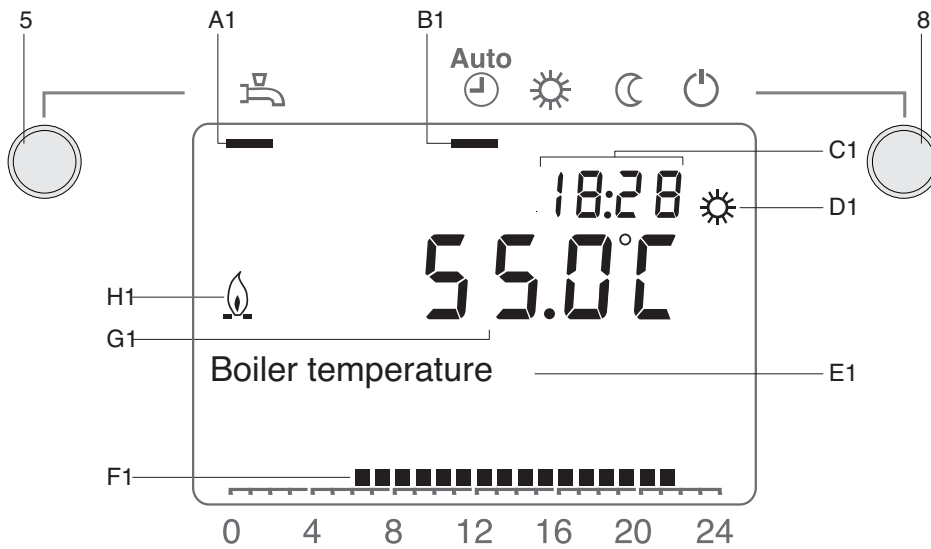

- A1 - DHW mode: ON or OFF
Press the DHW button (5) to switch DHW on or off (as shown by the line under the symbol)
- B1 - Central heating modes
Press the central heating mode button (8) to activate the various modes as shown by the line under the corresponding symbol
- C1 - Current time
- D1 - COMFORT heating mode
- E1 - Message area
- F1 - Daily heating program indicator
- G1 - Current boiler temperature
- H1 - Burner running

MODE SELECTION

Press the central heating mode button (5) to select the various modes. The active mode is shown by a line under the corresponding symbol.

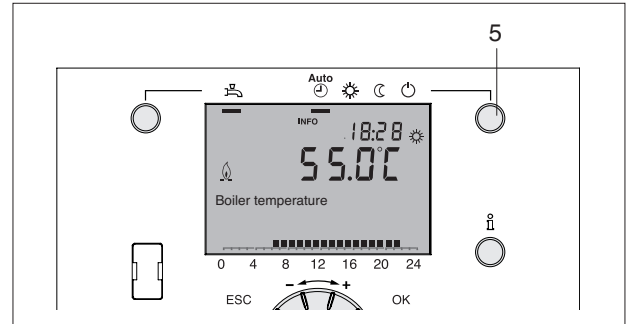

Automatic

In automatic mode, room temperature is controlled by the timer program.

Characteristics:

- Central heating operates according to the timer program.
- The temperature setpoint is set to comfort "☀" or reduced "☾".
- All protection functions are active.
- Summer/winter switching is automatic (ECO functions). Continuous operation of central heating is limited to 24h.

Continuous operation or

In continuous mode, room temperature is controlled on the basis of the comfort/reduced setting:

- ☀ Central heating set to comfort setpoint
- ☾ Central heating set to reduced setpoint

Characteristics:

- Central heating is continuously on with no time program.
- All protection functions are active.
- Summer/winter switching is automatic (ECO functions). Continuous central heating idle time is limited to 24h (see parameter 730).

Protection

In protection mode the central heating is switched off, but the system remains protected against frost (provided the electrical supply remains switched on).

Characteristics:

- Central heating is switched off.
- Temperature is set to the frost protection setpoint.
- All protection functions are active.

Domestic hot water (DHW)

Not used in this version.

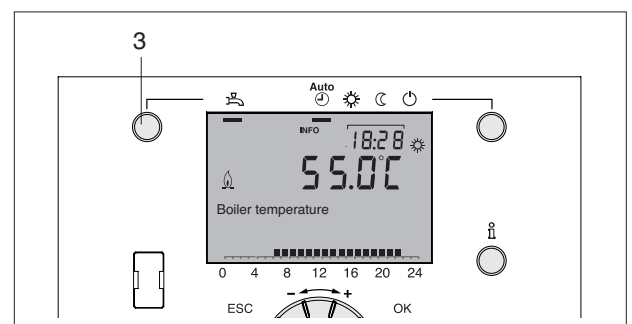

Setting the room temperature setpoint

Turn the knob (14) to set the desired room temperature comfort setpoint.

Proceed in a similar way to set the **room temperature reduced setpoint**:

- Press the "OK" button (13).
- Select "Heating circuit 1".
- Set the room temperature reduced setpoint.

⚠ After changing a setpoint, you need to wait about 2 hours for the new setting to have any effect on room temperature.

⚠ If no room unit is installed, changing the room temperature setpoint simply shifts the heating curve.

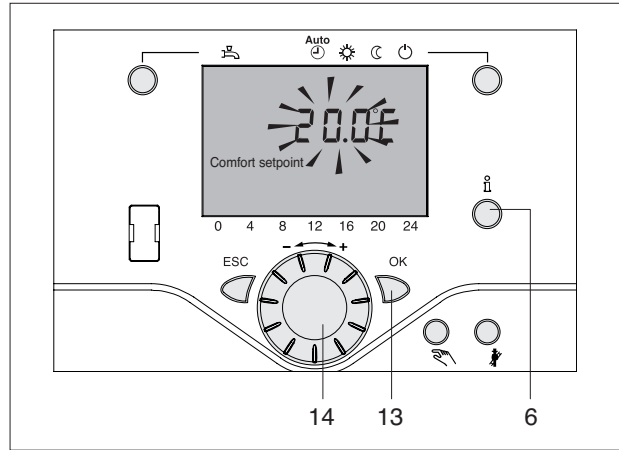

Information **i**

Press the information button (6) to display:

- Errors or maintenance codes (see the "Errors/Maintenance codes" section)
- Special messages.

Other screens:

⚠ Other displays depend on the system configuration and operational status. Some of the display lines shown below may not therefore appear.

- Room temperature
- Room temperature minimum
- Room temperature maximum
- Boiler temperature
- Outside temperature
- Outside temperature min
- Outside temperature max
- DHW temp 1
- State of heating circuit 1
- State of heating circuit 2 (not active)
- State heating circuit P
- State of DHW
- State of boiler
- State of solar
- State solid fuel boiler
- State buffer storage tank
- Date and time of day
- Telephone customer service

Manual mode



When you select manual mode, the "🔧" symbol appears and relays are energised/de-energised not according to any heating program but according to a setpoint value that can be set manually by pressing the information button (6).

Chimney sweep mode



To select chimney sweep mode, press the chimney sweep button (11) briefly (max. 3 seconds). The "🔧" symbol is displayed. Chimney sweep mode prepares the boiler for combustion analysis. To exit chimney sweep mode, press the button (11) again. The system exits chimney sweep mode automatically after 1 hour.

Safety thermostat test



To test the safety thermostat, press and hold the chimney sweep button (11) for longer than 3 seconds.

Hold the button down for the duration of the test.

The test terminates as soon as you release the button.

⚠ This test must only be performed by the **RIELO** Technical Assistance Service, since it raises boiler temperature over the normal permitted limits.

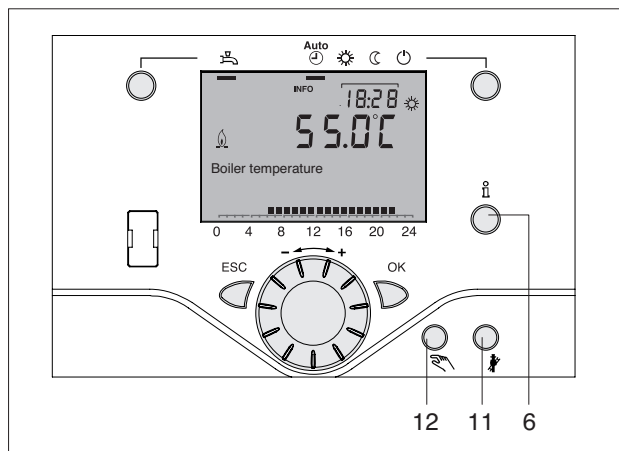

RESET function

The meters and parameter table RESET icon only appears in the bottom line of the display if it is possible to perform a reset in the current user level (End user, Commissioning, Heating engineer).

 This operation must only be performed by the **RIEHO** Technical Assistance Service. Performing a RESET restores all parameters to their default values, according to the "Complete list of parameters".

To perform a reset, press the "OK" button (13) when the "Yes" prompt flashes on the display.

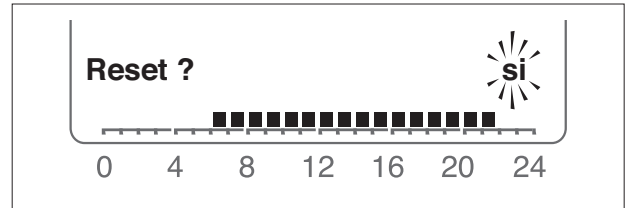
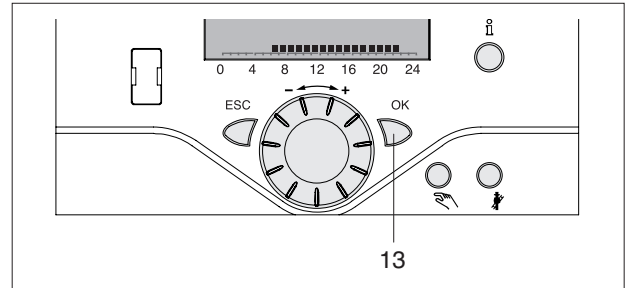

Special conditions



The following symbols can be displayed under certain conditions:



This symbol appears if a system error has occurred. Press button (6) for further information.



This symbol appears if a maintenance alarm is present or if the boiler has entered a special functioning mode. Press button (6) for further information.

If a system error or maintenance alarm occurs, contact RIEHO's Technical Assistance Service.

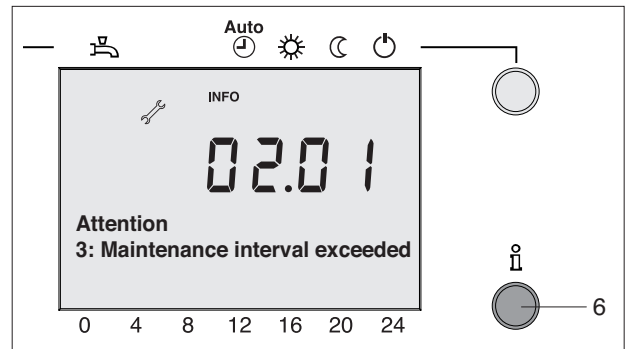
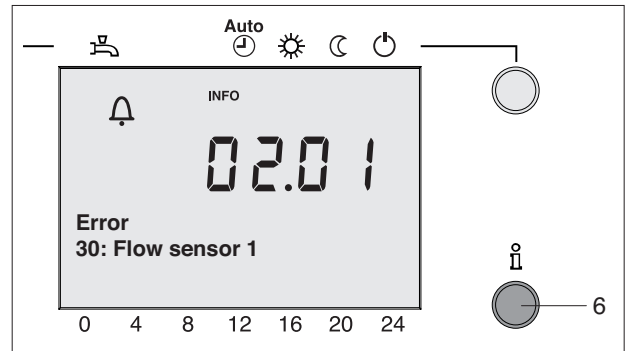

There are 4 different user levels:

- End user
- Commissioning
- Heating engineer
- OEM (Manufacturer).

The following parameters refer EXCLUSIVELY to the end user level.

Proceed as follows to access the user level you require.

- Go to the main screen.
If necessary, press the "ESC" button one or more times to return to the main screen.

Press the "OK" button.

Press and hold the information button "i" for 3 seconds.

- End user level. Turn the knob to scroll through the menu until you reach the end user programming level. Press "OK".

To enter the OEM level, you need to enter the

Password (12434)

Press the "OK" button to confirm each digit. Press "ESC" to cancel an entry.

- ⚠ - Pressing the "ESC" button takes you just one step back. The value entered is not saved.
- If no change is made for 8 minutes, the system returns to the main screen.
- Programming lines are displayed or hidden according to the system configuration and the user level (End user, Commissioning, etc.).

- ⚠ Parameter values on the Commissioning, Heating engineer and OEM levels must only be changed by the **RIELLO** Technical Assistance Service.

EXAMPLE: SETTING THE CURRENT TIME

- From the main screen press "OK".
- The message area displays a number of setting pages. Turn the knob until you reach the "Time of day and date" line. Press "OK" to confirm.

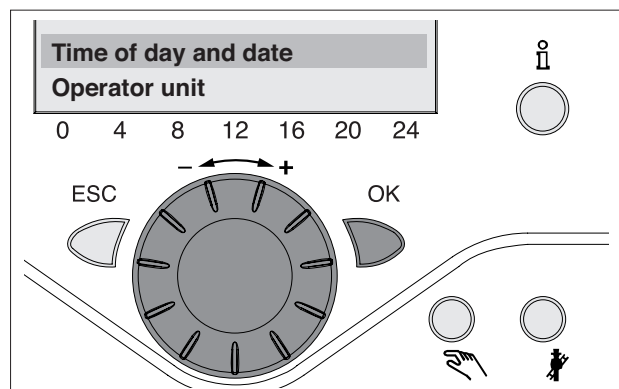
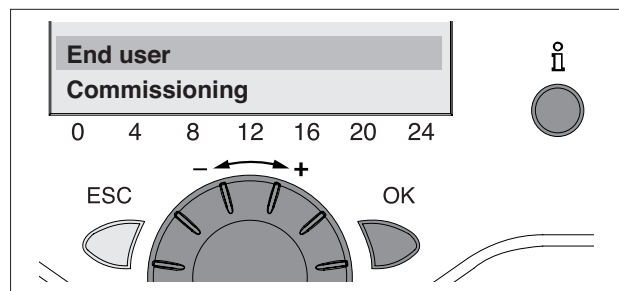
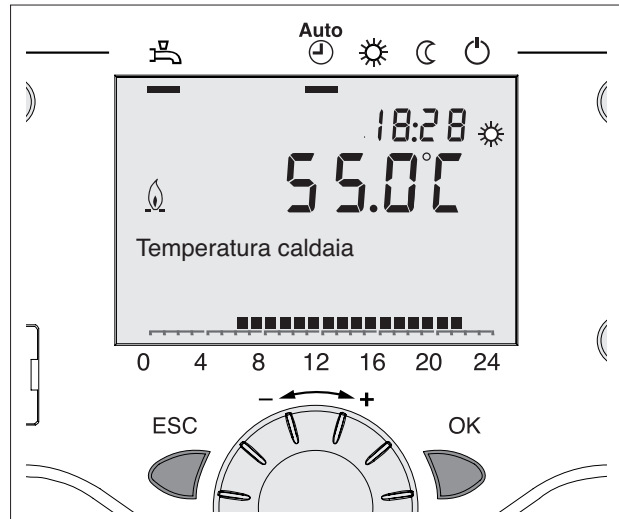

- The message area shows the current hour. Press "OK".

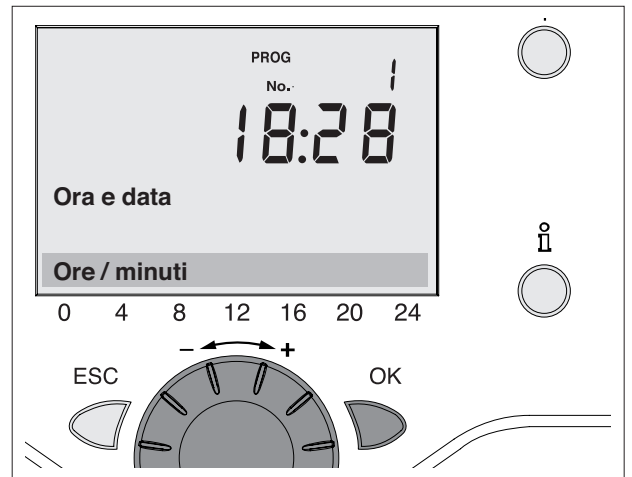

- The display starts to flash. Turn the knob to go on or back to the correct value. Press "OK" to confirm.

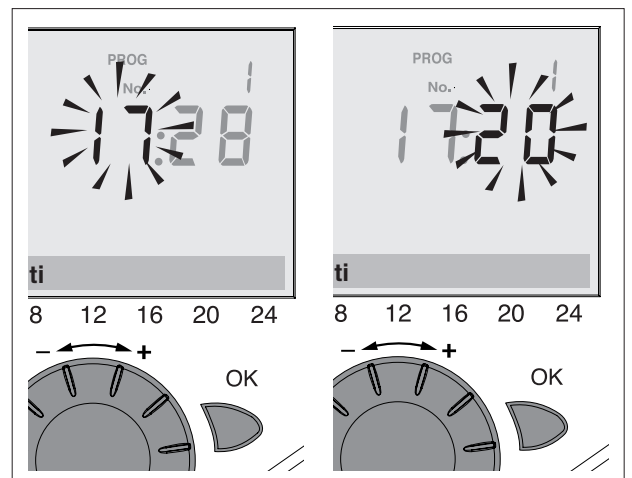

- The display flashes the current minutes. Turn the knob to go on or back to the correct value. Press "OK" to confirm.

The new time setting is saved and the display starts to flash. At this stage you can continue programming or press the central heating mode button (5) to return to the main screen.

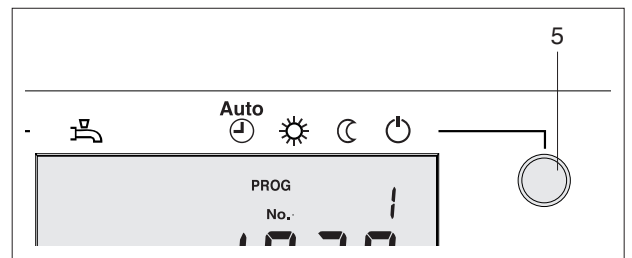

EXAMPLE OF THE MENU STRUCTURE

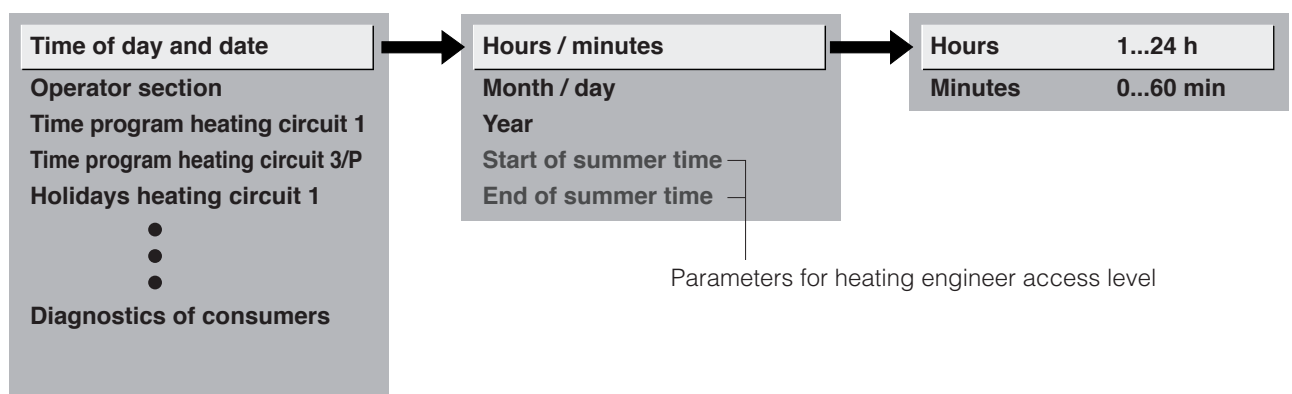

When the alarm symbol  warns of an error, press the button (6) to display a description. The message on the display describes the cause of the error.

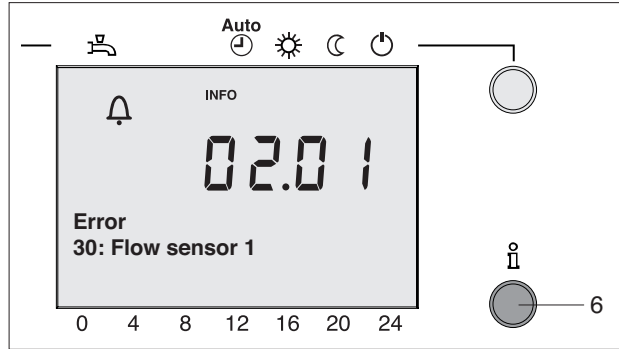

ERROR LIST

Error code	Description
0	No error
10	Outside temperature sensor error
20	Boiler temperature 1 sensor error
25	Solid fuel boiler temperature (wood) sensor error
26	Common flow temperature sensor error
28	Flue gas temperature sensor error
30	Flow temperature 1 sensor error
31	Flow temperature 1 cooling, sensor error
32	Flow temperature 2 sensor error
38	Flow temperature primary controller sensor error
40	Return temperature 1 sensor error
46	Return temperature cascade sensor error
47	Common return temperature sensor error
50	DHW temperature 1 sensor error
52	DHW temperature 2 sensor error
54	DHW primary controller sensor error
57	DHW circulation temperature sensor error
60	Room temperature 1 sensor error
65	Room temperature 2 sensor error
68	Room temperature 3 sensor error
70	Buffer storage tank temperature 1 sensor error
71	Buffer storage tank temperature 2 sensor error
72	Buffer storage tank temperature 3 sensor error
73	Collector temperature 1 sensor error
74	Collector temperature 2 sensor error
81	Short-circuit LPB
82	LPB address collision
83	BSB wire short-circuit
84	BSB address collision
85	BSB radio communication fault
98	Extension module 1 fault (common fault status message)
99	Extension module 2 fault (common fault status message)
100	2 clock time masters (LPB)
102	Clock time master without backup (LPB)
105	Maintenance message
109	Boiler temperature supervision
110	Lockout by SLT
117	Upper pressure limit (crossed)
118	Critical lower pressure limit (crossed)

Error code	Description
121	Flow temperature 1 (HC1) supervision
122	Flow temperature 2 (HC2) supervision
126	DHW charging supervision
127	Legionella temperature not reached
131	Burner fault
146	Configuration error common message
171	Alarm contact 1 (H1) active
172	Alarm contact 2 (H2) active
173	Alarm contact 3 (EX2/230VAC) active
174	Alarm contact 4 (H3) active
176	Upper pressure limit 2 (crossed)
177	Critical lower pressure limit 2 (crossed)
178	Temperature limiter heating circuit 1
179	Temperature limiter heating circuit 2
207	Error, cooling circuit
217	Sensor error common message
218	Pressure supervision common message
241	Flow sensor, solar sensor error
242	Return sensor, solar sensor error
243	Swimming pool temperature sensor error
320	DHW charging temperature sensor error
321	Instantaneous DHW heater outlet temperature sensor error
322	Upper pressure limit 3 (crossed)
323	Critical lower pressure limit 3 (crossed)
324	BX same sensors
325	BX/extension module same sensors
326	BX/mixing valve group same sensors
327	Extension module same function
328	Mixing valve group same function
329	Extension module / mixing valve group same function
330	Sensor BX1 no function
331	Sensor BX2 no function
332	Sensor BX3 no function
333	Sensor BX4 no function
334	Sensor BX5 no function
335	Sensor BX21 no function
336	Sensor BX22 no function
337	Sensor BX1 no function
338	Sensor BX12 no function
339	Collector pump Q5 missing
340	Collector pump Q16 missing
341	Collector sensor B6 missing
342	Solar DHW sensor B31 missing
343	Solar integration missing
344	Solar controlling element buffer K8 missing
345	Solar controlling element swimming pool K18 missing
346	Solid fuel boiler pump Q10 missing
347	Solid fuel boiler comparison sensor missing
348	Solid fuel boiler address error
349	Buffer return valve Y15 missing
350	Buffer storage tank address error
351	Primary controller / system pump address error

Error code	Description
352	Pressureless header address error
353	Cascade sensor B10 missing
357	Flow temperature cooling circuit 1 monitoring
366	Room temperature Hx sensor error
367	Relative room humidity Hx sensor error
368	Hx flow setpoint correction sensor error

MAINTENANCE CODE

Maintenance code	Description
1	Burner hours run exceeded
2	Burner starts exceeded
3	Maintenance interval exceeded
5	Water pressure heating circuit too low (dropped below lower pressure limit 1)
18	Water pressure 2 heating circuit too low (dropped below lower pressure limit 2)
10	Replace battery of outside sensor
21	Maximum flue gas temperature exceeded
22	Water pressure 3 heating circuit too low (dropped below lower pressure limit 3)

SPECIAL OPERATION CODE

Operation code	Description
301	Manual operation
302	SLT test
303	Chimney sweep function
309	Simulation outside temperature
310	Alternative energy operation
314	Economy mode

LIST OF PARAMETERS

Operating line	User level	Function	Default value	Min	Max	Unit
Time of day and date						
1	E	Hours / minutes	-	00:00	23:59	hh:mm
2	E	Day/month	-	01.01	31.12	dd.MM
3	E	Year	-	2004	2099	yyyy
5	F	Start of summertime	25.03	01.01	31.12	dd.MM
6	F	End of summertime	25.10	01.01	31.12	dd.MM
Operator unit						
20	E	Language German ...	German			-
21	O	Display special operation Off On	On			
22	F	Info Temporarily Permanently	Temporarily			-
26	F	Operation lock Off On	Off			-
27	F	Programming lock Off On	Off			-
28	I	Direct adjustment Automatic storage Save with acknowledgment	Save with acknowledgment			
30	O	Save basic settings No Yes	No			
31	O	Activate basic settings No Yes	No			
40 (*)	I	Used as Room unit 1 Room unit 2 Room unit P Operator unit 1 Operator unit 2 Operator unit P Service unit	Room unit 1			-
42(*)	I	Assignment device 1 Heating circuit 1 Heating circuits 1 and 2 Heating circuits 1 and P All heating circuits	Heating circuit 1			-
44	I	Operation HC2 Commonly with HC1 Independently	Commonly with HC1			-
46	I	Operation HCP Commonly with HC1 Independently	Commonly with HC1			-
48 (*)	I	Action occupancy button None Heating circuit 1 Heating circuit 2 Commonly	Heating circuit 1			-
54 (*)	F	Readjustment room sensor	0.0	-3	3	°C
70	F	Software version	-	0	99.9	-
Time prog heating circuit 1						
500	E	Preselection Mo - Su Mo - Fr Sa - Su Mo Tu We Th Fr Sa Su	Mo - Su			-
501	E	1st phase on	6:00	00:00	24:00	hh:mm
502	E	1st phase off	22:00	00:00	24:00	hh:mm
503	E	2nd phase on	24:00	00:00	24:00	hh:mm
504	E	2nd phase off	24:00	00:00	24:00	hh:mm
505	E	3rd phase on	24:00	00:00	24:00	hh:mm
506	E	3rd phase off	24:00	00:00	24:00	hh:mm
516	E	Default values No Yes	No			-

E=End user **I**=Commissioning **F**=Heating engineer **O**=OEM **BZ**=Operating line
 (*) QAA75../78.. only,

Operating line	User level	Function	Default value	Min	Max	Unit
Time prog heating circuit 2						
520	E	Preselection Mo - Su Mo - Fr Sa - Su Mo Tu We Th Fr Sa Su	Mo - Su			-
521	E	1st phase on	6:00	00:00	24:00	hh:mm
522	E	1st phase off	22:00	00:00	24:00	hh:mm
523	E	2nd phase on	24:00	00:00	24:00	hh:mm
524	E	2nd phase off	24:00	00:00	24:00	hh:mm
525	E	3rd phase on	24:00	00:00	24:00	hh:mm
526	E	3rd phase off	24:00	00:00	24:00	hh:mm
536	E	Default values No Yes	No			-
Time program 3/HCP						
540	E	Preselection Mo - Su Mo - Fr Sa - Su Mo Tu We Th Fr Sa Su	Mo - Su			-
541	E	1st phase on	6:00	00:00	24:00	hh:mm
542	E	1st phase off	22:00	00:00	24:00	hh:mm
543	E	2nd phase on	24:00	00:00	24:00	hh:mm
544	E	2nd phase off	24:00	00:00	24:00	hh:mm
545	E	3rd phase on	24:00	00:00	24:00	hh:mm
546	E	3rd phase off	24:00	00:00	24:00	hh:mm
556	E	Default values No Yes	No			-
Time program 4/DHW						
560	E	Preselection Mo - Su Mo - Fr Sa - Su Mo Tu We Th Fr Sa Su	Mo - Su			-
561	E	1st phase on	6:00	00:00	24:00	hh:mm
562	E	1st phase off	22:00	00:00	24:00	hh:mm
563	E	2nd phase on	24:00	00:00	24:00	hh:mm
564	E	2nd phase off	24:00	00:00	24:00	hh:mm
565	E	3rd phase on	24:00	00:00	24:00	hh:mm
566	E	3rd phase off	24:00	00:00	24:00	hh:mm
576	E	Default values No Yes	No			-
Time program 5						
600	E	Preselection Mo - Su Mo - Fr Sa - Su Mo Tu We Th Fr Sa Su	Mo - Su			-
601	E	1st phase on	6:00	00:00	24:00	hh:mm
602	E	1st phase off	22:00	00:00	24:00	hh:mm
603	E	2nd phase on	24:00	00:00	24:00	hh:mm
604	E	2nd phase off	24:00	00:00	24:00	hh:mm
605	E	3rd phase on	24:00	00:00	24:00	hh:mm
606	E	3rd phase off	24:00	00:00	24:00	hh:mm
616	E	Default values No Yes	No			-

E=End user I=Commissioning F=Heating engineer O=OEM BZ=Operating line
 (*) QAA75../78.. only,

Operating line	User level	Function	Default value	Min	Max	Unit
Holidays heating circuit 1						
641	E	Preselection Period 1 Period 2 Period 3 Period 4 Period 5 Period 6 Period 7 Period 8	Period 1			-
642	E	Start	--	01.01	31.12	dd.mm
643	E	End	--	01.01	31.12	dd.mm
648	E	Operating level Frost protection Reduced	Frost protection			-
Holidays heating circuit 2						
651	E	Preselection Period 1 Period 2 Period 3 Period 4 Period 5 Period 6 Period 7 Period 8	Period 1			-
652	E	Start	--	01.01	31.12	dd.mm
653	E	End	--	01.01	31.12	dd.mm
658	E	Operating level Frost protection Reduced	Frost protection			-
Holidays heating circuit P						
661	E	Preselection Period 1 Period 2 Period 3 Period 4 Period 5 Period 6 Period 7 Period 8	Period 1			-
662	E	Start	--	01.01	31.12	dd. mm
663	E	End	--	01.01	31.12	dd.mm
668	E	Operating level Frost protection Reduced	Frost protection			-
Heating circuit 1						
710	E	Comfort cooling setpoint	20.0	Operating line 712	Operating line 716	°C
712	E	Reduced setpoint	16	Operating line 714	Operating line 710	°C
714	E	Frost protection setpoint	10.0	4	Operating line 712	°C
716	F	Comfort setpoint maximum	35.0	Operating line 710	35	°C
720	E	Heating curve slope	1.50	0.10	4.00	-
721	F	Heating curve displacement	0.0	-4.5	4.5	°C
726	F	Heating curve adaptionOff On	Off			-
730	E	Summer/winter heating limit	18	--- / 8	30	°C
732	F	24-hour heating limit	-3	--- / -10	10	°C
740	I	Flow temp setpoint min	8	8	Operating line 741	°C
741	I	Flow temp setpoint max	80	Operating line 740	95	°C
750	F	Room influence	20	--- / 1	100	%
760	F	Room temp limitation	1	--- / 0.5	4	°C
770	F	Boost heating	5	--- / 0	20	°C
780	F	Quick setback Off Down to reduced setpoint Down to frost prot setp	Down to reduced setpoint			-
790	F	Optimum start control max	0	0	360	min
791	F	Optimum top control max	0	0	360	min
800	F	Reduced setp increase start	---	--- / -30	10	°C
801	F	Reduced setp increase end	-15	-30	Operating line 800	°C

E=End user **I**=Commissioning **F**=Heating engineer **O**=OEM **BZ**=Operating line
(*) QAA75../78.. only,

Operating line	User level	Function	Default value	Min	Max	Unit
820	F	Overtemp prot pump circuit Off On	On			-
830	F	Mixing valve boost	5	0	50	°C
832	F	Actuator type 2-position 3-position	3-position			-
833	F	Switching differential 2-pos	2	0	20	°C
834	F	Actuator running time	120	30	873	s
835	O	Mixing valve Xp	32	1	100	°C
836	O	Mixing valve Tn	120	10	873	s
850	I	Floor curing function Off Functional heating Curing heating Functional/ curing heating Curing/ functional heating Manually	Off			-
851	I	Floor curing setp manual	25	0	95	°C
861	F	Excess heat draw Off Heating mode Always	Always			
870	F	With buffer storage tank No Yes	Yes			-
872	F	With primary controller / system pump No Yes	Yes			
900	F	Optg mode changeover None Protection Reduced Comfort Automatic	Protection mode			
Cooling circuit 1						
901	E	Operating mode Off Automatic	Automatically			-
902	E	Comfort cooling setpoint	24.0	15	40	°C
907	E	release 24h/day Time programs HCs Time program 5	24 h/day			-
908	I	Flow setpoint at OT 25°C	20	8	35	°C
909	I	Flow setpoint at OT 35°C	16	8	35	°C
912	I	Cooling limit at OT (outside temperature)	20	--- / 8	355	°C
913	F	Locking period at end of heating	24	--- / 8	100	h
918	F	Start of summer compensation at OT	26	20	35	°C
919	F	End of summer compensation at OT	35	20	35	°C
920	F	Summer compensation setpoint increase	4	--- / 1	10	°C
923	I	Flow setpoint min. OT 25°C	18	8	35	°C
924	I	Flow setpoint min. OT 35°C	18	8	35	°C
928	F	Room influence	80	--- / 1	10	%
932	F	Room temp limitation	0.5	--- / 0.5	4	°C
938	F	Mixing valve subcooling	0	0	20	°C
939	F	Actuator type 2-position 3-position	3-position			
940	F	Switching differential 2-pos	2	0	20	°C
941	F	Actuator running time	120	30	873	s
942	O	Mixing valve Xp	12	1	100	°C
943	O	Mixing valve Tn	90	10	873	s
945	F	Mixing valve in heating mode Control Open	Controls			
946	F	Dewpt monitor locking time	60	--- / 10	600	min
947	F	Flow setpt increase hygro	3	--- / 1	10	°C
948	F	Start flow increase at R.H.	60	0	100	%

E=End user I=Commissioning F=Heating engineer O=OEM BZ=Operating line
 (*) QAA75../78.. only,

Operating line	User level	Function	Default value	Min	Max	Unit
950	I	Flow temp diff dewpoint	2	--- / 0	10	°C
962	F	With buffer storage tank No ; Yes	No			
963	F	With primary controller / system pump No ; Yes	No			
969	I	Optg mode changeover None ; Off ; Automatic	Off			
Heating circuit 2						
1010	E	Comfort cooling setpoint	20.0	Op line 1012	Operating line 1016	°C
1012	E	Reduced setpoint	16	Op line 1014	Operating line 1010	°C
1014	E	Frost protection setpoint	10.0	4	Operating line 1012	°C
1016	F	Comfort setpoint maximum	35.0	Op line 1010	35	°C
1020	E	Heating curve slope	1.50	0.10	4.00	-
1021	F	Heating curve displacement	0.0	-4.5	4.5	°C
1026	F	Heating curve adaption Off ; On	Off			-
1030	E	Summer/winter heating limit	18	--- / 8	30	°C
1032	F	24-hour heating limit	-3	--- / -10	10	°C
1040	I	Flow temp setpoint min	8	8	Operating line 1041	°C
1041	I	Flow temp setpoint max	80	Op line 1040	95	°C
1050	F	Room influence	20	--- / 1	100	%
1060	F	Room temp limitation	1	--- / 0.5	4	°C
1070	F	Boost heating	5	--- / 0	20	°C
1080	F	Quick setback Off ; Down to reduced setpoint ; Down to frost prot setp	Down to reduced setpoint			-
1090	F	Optimum start control max	0	0	360	min
1091	F	Optimum top control max	0	0	360	min
1100	F	Reduced setp increase start	---	--- / -30	10	°C
1101	F	Reduced setp increase end	-15	-30	Operating line 1100	°C
1120	F	Overtemp prot pump circuit Off ; On	On			-
1130	F	Mixing valve boost	5	0	50	°C
1132	F	Actuator type 2-position ; 3-position	3-position			-
1133	F	Switching differential 2-pos	2	0	20	°C
1134	F	Actuator running time	120	30	873	s
1135	O	Mixing valve Xp	32	1	100	°C
1136	O	Mixing valve Tn	120	10	873	s
1150	F	Floor curing function Off ; Functional heating ; Curing heating ; Functional/curing heating ; Curing/functional heating ; Manually	Off			-
1151	F	Floor curing setp manual	25	0	95	°C
1161	F	Excess heat draw Off ; Heating mode ; Always	Always			
1170	F	With buffer storage tank No ; Yes	Yes			-

E=End user **I**=Commissioning **F**=Heating engineer **O**=OEM **BZ**=Operating line
(*) QAA75../78.. only,

Operating line	User level	Function	Default value	Min	Max	Unit
1172	F	With primary controller / system pump No ; Yes	Yes			
1200	F	Optg mode changeover None ; Protection ; Reduced ; Comfort ; Automatic	Protection mode			
Heating circuit P						
1300	E	Operating mode Protection ; Automatic ; Reduced ; Comfort	Automatically			-
1310	E	Comfort cooling setpoint	20.0	Op line 1312	Operating line 1316	°C
1312	E	Reduced setpoint	16	Op line 1314	Operating line 1310	°C
1314	E	Frost protection setpoint	10.0	4	Operating line 1312	°C
1316	F	Comfort setpoint maximum	35.0	Op line 1310	35	°C
1320	E	Heating curve slope	1.50	0.10	4.00	-
1321	F	Heating curve displacement	0.0	-4.5	4.5	°C
1326	F	Heating curve adaption Off ; On	Off			-
1330	E	Summer/winter heating limit	18	--- / 8	30	°C
1332	F	24-hour heating limit	-3	--- / -10	10	°C
1340	F	Flow temp setpoint min	8	8	Operating line 1341	°C
1341	F	Flow temp setpoint max	80	Op line 1340	95	°C
1350	F	Room influence	20	--- / 1	100	%
1360	F	Room temp limitation	1	--- / 0.5	4	°C
1370	F	Boost heating	5	--- / 0	20	°C
1380	F	Quick setback Off ; Down to reduced setpoint ; Down to frost prot setp	Down to reduced setpoint			-
1390	F	Optimum start control max	0	0	360	min
1391	F	Optimum top control max	0	0	360	min
1400	F	Reduced setp increase start	---	--- / -30	10	°C
1401	F	Reduced setp increase end	-15	-30	Operating line 1400	°C
1420	F	Overtemp prot pump circuit Off ; On	On			-
1450	I	Floor curing function Off ; Functional heating ; Curing heating ; Functional/ curing heating; Curing/ functional heating ; Manually	Off			-
1451	I	Floor curing setp manual	25	0	95	°C
1455	F	Floor curing setp current	0	0	95	°C
1456	F	Floor curing day current	0	0	32	
1457	F	Floor curing days complete	0	0	32	
1461	F	Excess heat draw Off ; Heating mode ; Always	Always			
1470	F	With buffer storage tank No ; Yes	Yes			-
1472	F	With primary controller / system pump No ; Yes	Yes			

E=End user I=Commissioning F=Heating engineer O=OEM BZ=Operating line
(*) QAA75../78.. only,

Operating line	User level	Function	Default value	Min	Max	Unit
1500	F	Optg mode changeover None ; Protection ; Reduced ; Comfort ; Automatic	Protection mode			
DHW						
1610	E	Nominal setpoint	55	Op line 1612	BZ 1614 OEM	°C
1612	F	Reduced setpoint	40	8	Operating line 1610	°C
1614	O	Nominal setpoint max	65	8	80	°C
1620	O	Release 24h/day ; Time programs HCs ; Time program 4/DHW	Time programs HCs			-
1630	I	Charging priority Absolute ; Shifting ; None ; MC shifting, PC absolute	MC shifting, PC ab- solute			-
1640	F	Legionella function Off ; Periodically ; Fixed weekday	Fixed weekday			-
1641	F	Legionella funct periodically	3	1	7	Days
1642	F	Legionella funct weekday Monday ; Tuesday ; Wednesday ; Thursday ; Friday ; Saturday ; Sunday	Monday			
1644	F	Legionella function time	- - -	- - - / 00:00	23:50	hh:mm
1645	F	Setpoint of Legionella function	65	55	95	°C
1646	F	Legionella function dwelling time	30	- - - / 10	360	min
Pumps H						
2008	O	H1 DHW charging priority No ; Yes	Yes			
2010	F	H1 Excess heat draw Off ; On	On			
2012	F	H1 with buffer storage tank No ; Yes	Yes			-
2014	F	H1 prim contr/system pump No ; Yes	Yes			-
2015	F	H1 Refrig demand 2-pipe system ; 4-pipe system	2-pipe system			
2033	O	H2 DHW charging priority No ; Yes	Yes			
2035	F	H2 Excess heat draw Off ; On	On			
2037	F	H2 with buffer storage tank No ; Yes	Yes			-
2039	F	H2 prim contr/system pump No ; Yes	Yes			-
2040	F	H2 Refrig demand 2-pipe system ; 4-pipe system	2-pipe system			
Primary controller / system pump						
2110	O	Flow temp setpoint min	8	8	95	°C
2111	O	Flow temp setpoint max	80	8	95	°C
2112	O	Flow setpoint, cooling min	8	8	20	°C
2130	O	Mixing valve boost	10	0	50	°C
2131	O	Mixing valve subcooling	0	0	20	°C
2132	O	Actuator type 2-position ; 3-position	3-position			

E=End user **I**=Commissioning **F**=Heating engineer **O**=OEM **BZ**=Operating line
(*) QAA75../78.. only,

Operating line	User level	Function	Default value	Min	Max	Unit
2133	O	Switching differential 2-pos	2	0	20	°C
2134	O	Actuator running time	120	30	873	s
2135	O	Mixing valve Xp	32	1	100	°C
2136	O	Mixing valve Tn	120	10	873	s
2150	I	Primary controller / system pump Before buffer st tank After buffer st tank	After buffer st tank			
Configuration						
5710	I	Heating circuit 1 Off On	On			-
5711	I	Cooling circuit 1 Off 4-pipe system 2-pipe system				
5712	I	Use of mixing valve 1 Heating Cooling Heating and cooling	Heating and cooling			
5715	I	Heating circuit 2 Off On	Off			-
5950	I	Function of input H1 Optg mode changeover HCs + DHW Optg mode changeover HCs Optg mode changeover HC1 Optg mode changeover HC2 Optg mode changeover HCP Error/alarm message Min flow temp setpoint Excess heat discharge Dewpoint monitor Flow setp increase hygro Refrig demand Heat request 10V Refrig. demand 10V Pressure measurement 10V Rel. room humidity 10V Room temperature 10V	Optg mode change- over HCs+DHW			-
5951	I	Contact type H1 NC NO	NO			-
5952	I	Function value, contact type H1	70	8	130	°C
5953	I	Voltage value 1, H1		0	10	Volt
5954	I	Function value 1, H1		-100	500	-
5955	I	Voltage value 2, H1		0	10	Volt
5956	I	Function value 2, H1		-100	500	-
6014	I	Function mixing group 1 Heating circuit 1 Return temp controller Prim contr/system pump Cooling circuit 1 Heating circuit / Cooling circuit 1)	Heating circuit			-
6020	I	Function extension module 1 None Multifunctional Heating circuit 2 Prim contr/system pump Cooling circuit 1	None			-
6021	I	Function extension module 1 None Multifunctional Heating circuit 2 Prim contr/system pump Cooling circuit 1	None			-
6030	I	Relay output QX21 None H1 pump Q15 Alarm output K10 2nd pump speed HC1 Q21 2nd pump speed HC2 Q22 2nd pump speed HCP Q23 Heat circuit pump HCP Q20 H2 pump Q18 System pump Q14 Time program 5 K13 Heat request K27 Refrig. request K28 Air dehumidif. K29 Diverting valve, cooling Y21	None			

E=End user I=Commissioning F=Heating engineer O=OEM BZ=Operating line
(*) QAA75../78.. only,

Operating line	User level	Function	Default value	Min	Max	Unit
6031	I	Relay output QX22 None ; H1 pump Q15 ; Alarm output K10 ; 2nd pump speed HC1 Q21 ; 2nd pump speed HC2 Q22 ; 2nd pump speed HCP Q23 ; Heat circuit pump HCP Q20 ; H2 pump Q18 ; System pump Q14 ; Time program 5 K13 ; Heat request K27 ; Refrig. request K28 ; Air dehumidif. K29 ; Diverting valve, cooling Y21	None			
6032	I	Relay output QX23 None ; H1 pump Q15 ; Alarm output K10 ; 2nd pump speed HC1 Q21 ; 2nd pump speed HC2 Q22 ; 2nd pump speed HCP Q23 ; Heat circuit pump HCP Q20 ; H2 pump Q18 ; System pump Q14 ; Time program 5 K13 ; Heat request K27 ; Refrig. request K28 ; Air dehumidif. K29 ; Diverting valve, cooling Y21	None			
6046	I	Function of input H2 Optg mode changeover HCs + DHW ; Optg mode changeover HCs ; Optg mode changeover HC1 ; Optg mode changeover HC2 ; Optg mode changeover HCP ; Error/alarm message ; Min flow temp setpoint ; Excess heat discharge ; Dewpoint monitor ; Flow temp. setpt increase, hygro ; Refrig request ; Heat request 10V ; Refrig. request 10V ; Pressure measurement 10V ; Rel. room humidity 10V ; Room temperature 10V	Optg mode change-over HCs+DHW			
6047	I	Contact type H2 NC ; NO	NO			-
6048	I	Function value, contact H2	70	8	130	°C
6049	I	Voltage value 1, H2	0	0	10	Volt
6050	I	Function value 1, H2	0	-100	500	-
6051	I	Voltage value 2, H2	10	0	10	Volt
6052	I	Function value 2, H2	70	-100	500	-
6100	F	Readjustm outside sensor	0	-3.0	3.0	°C
6110	F	Time constant building	15	0	50	h
6112	O	Gradient room model	60	0	300	Min/°C
6120	F	Frost protection for the plant Off ; On	Off			-
6128	F	Heat request below OT	---	--- / -50	50	°C
6129	F	Heat request above OT	---	--- / -50	50	°C
6135	F	Air dehumidifier Off ; On	Off			
6136	F	Air dehumidifier enable 24h/day ; Time progr. heating circuit ; Time program 5	24 h/day			
6137	F	Air dehumidifier r.h. ON	55	0	100	%
6138	F	Air dehumidifier r.h. SD	5	2	50	%
6140	O	Water pressure max	---	--- / 0.0	10.0	bar
6141	O	Water pressure min	---	--- / 0.0	10.0	bar

E=End user **I**=Commissioning **F**=Heating engineer **O**=OEM **BZ**=Operating line
(*) QAA75../78.. only,

Operating line	User level	Function	Default value	Min	Max	Unit
6142	O	Water pressure critical min	---	--- / 0.0	10.0	bar
6150	O	Water pressure 2 max	---	--- / 0.0	10.0	bar
6151	O	Water pressure 2 min	---	--- / 0.0	10.0	bar
6152	O	Water press 2 critical min	---	--- / 0.0	10.0	bar
6200	I	Save sensors No Yes	No			-
6204	O	Save parameters No Yes	No			
6205	F	Reset to default parameters No Yes	No			-
6215	I	Check-No. storage tank	-	0	199999	-
6217	I	Check-No. heating circuits	-	0	199999	-
6220	F	Software version	-	0	99.9	-
6222	O	Device hours run	0	0	65535	h
LPB system						
6600	I	Device address	1	0	16	-
6601	F	Segment address	0	0	14	-
6604	F	Bus power supply function Off Automatically	Automatically			-
6605	F	Bus power supply state Off On	On			-
6610	O	Display system messages No Yes	Yes			
6612	O	Alarm delay	---	--- / 2	60	min
6620	F	Action changeover functions Segment System	System			-
6621	F	Summer changeover Locally Centrally	Locally			-
6623	F	Optg mode changeover Locally Centrally	Centrally			
6625	F	Assignment of DHW heating Local HCs All HCs in segment All HCs in system	All HCs in system			-
6627	F	Refrigeration demand Locally Centrally	Locally			
6640	I	Clock mode Autonomously Slave without remote Slave with remote setting Master	Autonomously			-
6650	F	Outside temp source	0	0	239	-
Errors						
6710	I	Reset alarm relay No Yes	No			-
6740	F	Flow temp 1 alarm	---	--- / 10	240	min
6741	F	Flow temp 2 alarm	---	--- / 10	240	min
6746	F	Flow temp alarm, cooling 1	---	--- / 10	240	min
6800	F	History 1	-			
	F	Error code 1	-	0	255	-
6802	F	History 2	-			
	F	Error code 2	-	0	255	-

E=End user I=Commissioning F=Heating engineer O=OEM BZ=Operating line
 (*) QAA75../78.. only,

Operating line	User level	Function	Default value	Min	Max	Unit
6804	F	History 3	-			
	F	Error code 3	-	0	255	-
6806	F	History 4	-			
	F	Error code 4	-	0	255	-
6808	F	History 5	-			
	F	Error code 5	-	0	255	-
6810	F	History 6	-			
	F	Error code 6	-	0	255	-
6812	F	History 7	-			
	F	Error code 7	-	0	255	-
6814	F	History 8	-			
	F	Error code 8	-	0	255	-
6816	F	History 9	-			
	F	Error code 9	-	0	255	-
6818	F	History 10	-			
	F	Error code 10	-	0	255	-
6820	O	Reset history No Yes	No			-
Maintenance / special operation						
7044	F	Maintenance interval	- - -	- - - / 1	240	Months
7045	F	Time since maintenance	0	0	240	Months
7140	E	manual operation Off On	Off			-
7150	I	Simulation outside temperature	-	-50.0	50	°C
7170	I	Telephone customer service				-
Input / output test						
7700	I	Relay test No test Everything off DHW pump Q3 Heating circuit pump Q2 Heat circ mix valve op Y1 Heat circ mix valve cl Y2 Relay output QX21 module 1 Relay output QX22 module 1 Relay output QX23 module 1 Relay output QX21 module 2 Relay output QX22 module 2 Relay output QX23 module 2	No test			-
7730	I	Outside temp B9	-	-50.0	50	°C
7732	I	Flow temp B1	-	0.0	140	°C
7841	I	Contact state H1 Open Closed	-			-
7845	I	Voltage signal H2	0	0	10	°C
7846	I	Contact state H2 Open Closed	-			-
State						
8000	I	State of heating circuit 1	-			-
8001	I	State of heating circuit 2	-			-
8002	I	State heating circuit P	-			-
8003	I	State of DHW	-			-
8004	I	State of cooling circuit	-			-
Diagnostics, consumers						
8700	I	Outside temperature (OT)	-	-50.0	50.0	°C
8703	I	Outside temp attenuated	-	-50.0	50.0	°C
8704	I	Outside temperature composite	-	-50.0	50.0	°C

E=End user **I**=Commissioning **F**=Heating engineer **O**=OEM **BZ**=Operating line
(*) QAA75../78.. only,

Operating line	User level	Function	Default value	Min	Max	Unit
8720	I	Relative room humidity	-	0	100	%
8721	I	Outside temperature (OT)	-	0	50.0	°C
8722	I	Dewpoint temperature 1	-	0	50.0	°C
8730	I	Heating circuit pump Q2 Off On	-			-
8731	I	Heating circ mix valve op Y1 Off On	-			-
8732	I	Heat circ mix valve cl Y2 Off On	-			-
8740	I	Room temp 1	-	0.0	50.0	°C
8741	I	Room setpoint 1	-	4.0	35.0	°C
8742	O	Room temp 1 model	-	0.0	50.0	°C
8743	I	Flow temperature 1	-	0.0	140.0	°C
8744	I	Flow temp setpoint 1	-	0.0	140.0	°C
8751	I	Cooling circuit pump 1 Off On	-			
8752	I	Cooling circuit mixing valve 1 Open Off On	-			
8753	I	Cooling circuit mixing valve 1 Closed Off On	-			
8754	I	Cooling diverting valve 1 Off On	-			
8756	I	Flow temperature, cooling 1	-	0	140	°C
8757	I	Flow temperature, cooling 1	-	0	140	°C
8760	I	Heating circuit pump 2 Off On	-			-
8761	I	Heat circ mix valve 2 open Off On	-			-
8762	I	Heat circ mix valve 2 close Off On	-			-
8770	I	Room temp 2	-	0.0	50	°C
8771	I	Room setpoint 2	-	4.0	35	°C
8772	O	Room temp 2 model	-	0.0	50	°C
8773	I	Flow temperature 2	-	0.0	140	°C
8774	I	Flow temp setpoint 2	-	0.0	140	°C
8800	I	Room temp P	-	0.0	50	°C
8801	I	Room setpoint P	-	4.0	35	°C
8802	O	Room temp P model	-	0.0	50	°C
8803	I	Flow temp setpoint P	-	0.0	140	°C
8830	I	DHW temp 1	-	0.0	140	°C
8831	I	DHW temp setpoint	-	8.0	80	°C
8930	I	Primary controller temp	-	0.0	140.0	°C
8931	I	Primary controller setpoint	-	0.0	140.0	°C
9000	I	Flow temperature setpoint H1	-	5.0	130.0	°C
9001	I	Flow temp setpoint H2	-	5.0	130.0	°C
9005	I	Water pressure H1	-	0.0	10.0	bar
9006	I	Water pressure H2	-	0.0	10.0	bar
9050	I	Relay output QX21 module 1 Off On	-			-
9051	I	Relay output QX22 module 1 Off On	-			-
9052	I	Relay output QX23 module 1 Off On	-			-
9053	I	Relay output QX21 module 2 Off On	-			-

E=End user I=Commissioning F=Heating engineer O=OEM BZ=Operating line
 (*) QAA75../78.. only,

Operating line	User level	Function	Default value	Min	Max	Unit
9054	I	Relay output QX22 module 2 Off On	-			-
9055	I	Relay output QX23 module 2 Off On	-			-

E=End user **I**=Commissioning **F**=Heating engineer **O**=OEM **BZ**=Operating line
 (*) QAA75../78.. only,



**Instructions for the correct disposal of the product
pursuant to European Directive 2002/96/EC**

At the end of its working life, the product cannot be disposed of as municipal waste. It can be delivered to separate waste collection centres operated by local councils, if such exist, or to the resellers that provide this service. Separate disposal of appliances avoids possible negative consequences for the environment and the health due to unsuitable disposal and allows the recovery of the components, with significant savings in terms of energy and resources. The symbol (crossed-out wheeled bin) shown on the product indicates that the appliance must be disposed of separately.



RIELLO S.p.A.
37045 Legnago (VR)
Tel. 0442630111 - Fax 044222378 - www.riello.it

**As part of the company's ongoing commitment to perfecting its range of products,
the appearance, dimensions, technical data, equipment and accessories
may be subject to variation.**